

## BLOCKS- HI-LIFT BLOCKS

### Wide capacity range available

- Standard capacities to 300T
- Design factor 4:1
- Larger capacities available
- Sheaves from 8" to 36"
- Wire rope sizes to 1 ¾"

### Hooks- high quality forged alloy steel

- Per DIN 15401 or DIN 15402
- Other hook standards available
- Heavy duty thrust bearing
- Dual motion- swing plus 360° rotation
- Safety latch on all hooks
- Double and other hooks available

### Heavy welded steel plate construction

- provides rigidity and strength for longer life
- Designed for shortest possible overall length
- Enclosed sheave guard for easier threading- eliminates possibility of rope jumping sheave
- "H" models provide additional overhaul weight with detachable steel cheek plates
- "T" and "TF", extended or standard side plates- on 24" sheave models

### Bearings and sheaves

- For sheave sizes 20" and below, hardened and ground sheave pin with roller bearings
- For sheaves 24" and higher, tapered roller bearings with lip seals on alloy steel sheave pin
- Bronze bushings optional
- Individual sheave lubrication for assured grease penetration.
- Heavy duty cast steel sheaves standard, roll formed/welded sheaves available
- Bronze spacers between sheaves eliminate galling

### Options available

- Double hooks
- Higher load capacities
- Fittings other than hook
- Hook rotation locking device
- Third party certifications
- Cast hooks (quad)
- Custom

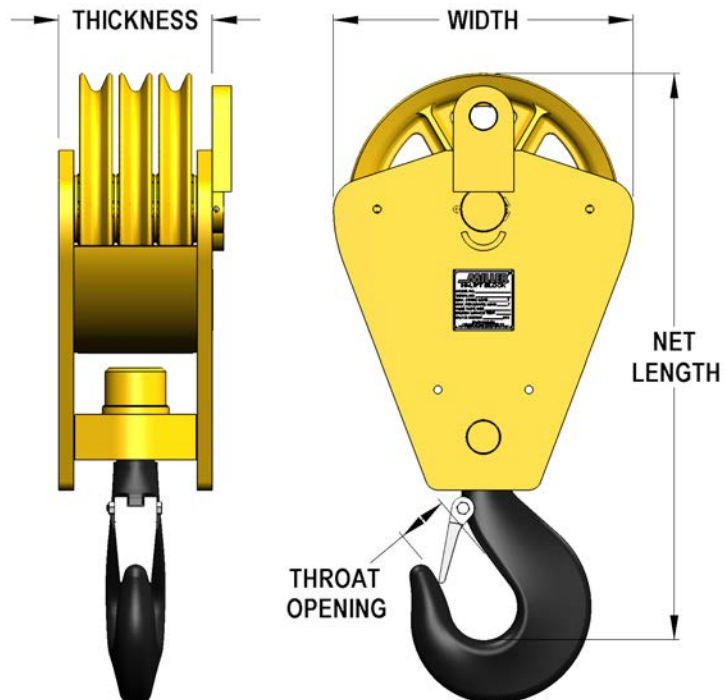

# BLOCKS- HI-LIFT BLOCKS

MILLER Block Model Number Key						
#	##	XX	-	###	-	XX
(Number of Sheaves)	(Sheave Outside Diameter (in))*	(Configuration)**		(Working load limit)***		(Special Designation)****
<p>*Standard Outside Diameter Sheave Range from 8 to 36"</p> <p>**Block Configuration Options:</p> <p><b>F</b> - Roller Bearing Mounted Sheaves, Low Profile Side Plates</p> <p><b>H</b> - Roller Bearing Mounted Sheaves, Low Profile Side Plates, Cheek weights</p> <p><b>TF</b> - Tapered Roller Bearing Mounted Sheaves, Low Profile Side Plates</p> <p><b>T</b> - Tapered Roller Bearing Mounted Sheaves, Extended Side Plates</p> <p>***Working Load Limit Range from 5 to 300T</p> <p>****Special Designations:</p> <p><b>RT</b> - Round Top Side Plates</p> <p><b>LD</b> - Locking Device, 4 Positions</p>						
<p>****Specify Wire Rope Size When Ordering****</p>						

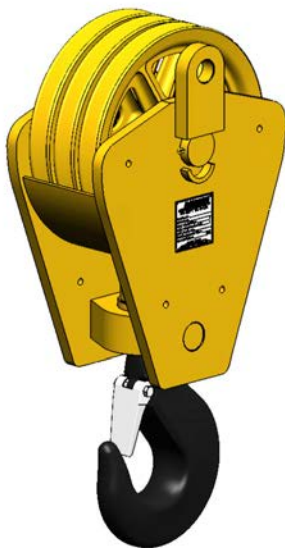

MODEL NO: 318F40  
 -3 SHEAVES, 18" DIAMETER  
 -LOW PROFILE SIDE PLATES  
 -40 TON WLL



MODEL NO: 520H80  
 -5 SHEAVES, 20" DIAMETER  
 -CHEEK WEIGHTS  
 -80 TON WLL

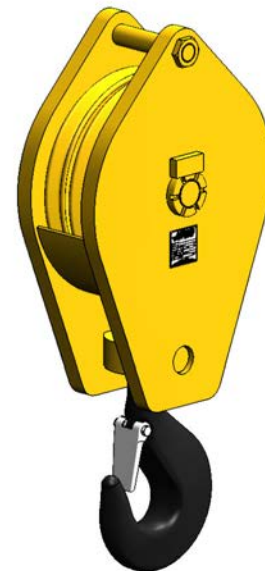

MODEL NO: 224T50  
 -2 SHEAVES, 24" DIAMETER  
 -EXTENDED SIDE PLATES  
 -50 TON WLL



# BLOCKS- HI-LIFT BLOCKS

## 5 TON

WLL* Tons	Model Number	SHEAVE DIA. (in.)	# OF SHEAVES	THICKNESS (in.)	WIDTH (in.)	NET LENGTH (in.)	THROAT OPENING (in.)	SHEAVE PIN DIA. (in.)	STD WIRE ROPE DIA. (in.)	Weight Lbs.
5	108F5	8	1	5.75	9.5	17.5	1.88	1.63	7/16	70
5	108H5	8	1	8.75	9.5	17.5	1.88	1.63	7/16	120
5	110F5	10	1	9.5	11.5	19	1.88	1.63	9/16	90
5	110H5	10	1	13	11.5	19	1.88	1.63	9/16	160
5	112F5	12	1	7.5	13.5	22.5	1.88	2.5	5/8	140
5	112H5	12	1	10.5	13.5	22.5	1.88	2.5	5/8	240
5	114F5	14	1	7.5	15.5	27.06	1.88	2.5	3/4	160
5	114H5	14	1	11	15.5	27.06	1.88	2.5	3/4	320
5	208F5	8	2	5.75	9.5	19.75	1.88	1.63	7/16	80
5	208H5	8	2	8.75	9.5	19.75	1.88	1.63	7/16	130

## 10 TON

WLL* Tons	Model Number	SHEAVE DIA. (in.)	# OF SHEAVES	THICKNESS (in.)	WIDTH (in.)	NET LENGTH (in.)	THROAT OPENING (in.)	SHEAVE PIN DIA. (in.)	STD WIRE ROPE DIA. (in.)	Weight Lbs.
10	108F10	8	1	5.75	9.5	19.75	2.5	1.63	7/16	80
10	108H10	8	1	8.75	9.5	19.75	2.5	1.63	7/16	130
10	110F10	10	1	6	11.5	22	2.5	1.63	9/16	100
10	110H10	10	1	9.5	11.5	22	2.5	1.63	9/16	170
10	112F10	12	1	7.5	13.5	24.75	2.5	2.5	5/8	150
10	112H10	12	1	10.5	13.5	24.75	2.5	2.5	5/8	250
10	114F10	14	1	7.5	15.5	27.75	2.5	2.5	3/4	170
10	114H10	14	1	11	15.5	27.75	2.5	2.5	3/4	330
10	116F10	16	1	8.75	17.5	30.56	2.5	3	7/8	250
10	116H10	16	1	13.75	17.5	30.56	2.5	3	7/8	490
10	118F10	18	1	8.75	19.5	32.75	2.5	3	7/8	285
10	118H10	18	1	12.75	19.5	32.75	2.5	3	7/8	585
10	208F10	8	2	5.75	9.5	19.75	2.5	1.63	7/16	85
10	208H10	8	2	8.75	9.5	19.75	2.5	1.63	7/16	135
10	210F10	10	2	6	11.5	22	2.5	1.63	9/16	110
10	210H10	10	2	9.5	11.5	22	2.5	1.63	9/16	180
10	212F10	12	2	7.5	13.5	24.75	2.5	2.5	5/8	165
10	212H10	12	2	10.5	13.5	24.75	2.5	2.5	5/8	265
10	214F10	14	2	7.5	15.5	28	2.5	2.5	3/4	215
10	214H10	14	2	11	15.5	28	2.5	2.5	3/4	365
10	308F10	8	3	7.25	9.5	19.75	2.5	1.63	7/16	95
10	308H10	8	3	10.25	9.5	19.75	2.5	1.63	7/16	145
10	310F10	10	3	7.5	11.5	22	2.5	1.63	9/16	125
10	310H10	10	3	11	11.5	22	2.5	1.63	9/16	195
10	312F10	12	3	9.75	13.5	24.75	2.5	2.5	5/8	210
10	312H10	12	3	12.75	13.5	24.75	2.5	2.5	5/8	310

# BLOCKS- HI-LIFT BLOCKS

## 15 TON

WLL* Tons	Model Number	SHEAVE DIA. (in.)	# OF SHEAVES	THICKNESS (in.)	WIDTH (in.)	NET LENGTH (in.)	THROAT OPENING (in.)	SHEAVE PIN DIA. (in.)	STD WIRE ROPE DIA. (in.)	Weight Lbs.
15	114F15	14	1	7.5	15.5	29.63	3.38	2.5	3/4	215
15	114H15	14	1	11	15.5	29.63	3.38	2.5	3/4	365
15	116F15	16	1	8.75	17.5	32.5	3.38	3	7/8	265
15	116H15	16	1	13.75	17.5	32.5	3.38	3	7/8	585
15	118F15	18	1	8.75	19.5	34.5	3.38	3	7/8	305
15	118H15	18	1	12.75	19.5	34.5	3.38	3	7/8	605
15	210F15	10	2	7.5	11.5	25	3.38	1.63	9/16	120
15	212F15	12	2	7.5	11.5	26.88	3.38	2.5	5/8	185
15	212H15	12	2	10.5	13.5	26.88	3.38	2.5	5/8	285
15	214F15	14	2	7.5	15.5	27.06	3.38	2.5	3/4	220
15	214H15	14	2	11	15.5	27.06	3.38	2.5	3/4	380
15	216F15	16	2	8.75	17.5	32.5	3.38	3	7/8	315
15	216H15	16	2	13.75	17.5	32.5	3.38	3	7/8	555
15	310F15	10	3	7.5	11.5	22	3.38	1.63	9/16	125
15	310H15	10	3	11	11.5	22	3.38	1.63	9/16	195
15	312F15	12	3	9.75	13.5	27.06	3.38	2.5	5/8	220
15	312H15	12	3	12.75	13.5	27.06	3.38	2.5	5/8	320
15	314F15	14	3	9.75	15.5	29.5	3.38	2.5	3/4	255
15	314H15	14	3	13	15.5	29.5	3.38	2.5	3/4	415

## 20 TON

WLL* Tons	Model Number	SHEAVE DIA. (in.)	# OF SHEAVES	THICKNESS (in.)	WIDTH (in.)	NET LENGTH (in.)	THROAT OPENING (in.)	SHEAVE PIN DIA. (in.)	STD WIRE ROPE DIA. (IN.)	Weight Lbs.
20	114F20	14	1	7.5	15.5	29.5	3.38	2.5	3/4	215
20	114H20	14	1	11	15.5	29.5	3.38	2.5	3/4	365
20	116F20	16	1	8.75	17.5	32.69	3	3	7/8	265
20	116H20	16	1	13.75	17.5	32.69	3	3	7/8	505
20	118F20	18	1	8.75	19.5	34.25	3	3	7/8	305
20	118H20	18	1	12.75	19.5	34.25	3	3	7/8	605
20	214F20	14	2	7.5	15.5	29.5	3	2.5	3/4	220
20	214H20	14	2	11	15.5	29.5	3	2.5	3/4	380
20	216F20	16	2	8.75	17.5	32.69	3	3	7/8	315
20	216H20	16	2	13.75	17.5	32.69	3	3	7/8	555
20	218F20	18	2	8.75	19.5	34.25	3	3	7/8	340
20	218H20	18	2	12.75	19.5	34.25	3	3	7/8	640
20	312F20	12	3	9.75	13.5	27.06	3	2.5	5/8	220
20	312H20	12	3	12.75	13.5	27.06	3	2.5	5/8	320
20	314F20	14	3	9.75	15.5	29.5	3	2.5	3/4	255
20	314H20	14	3	13.25	15.5	29.5	3	2.5	3/4	415



# BLOCKS- HI-LIFT BLOCKS

## 25 TON

WLL* Tons	Model Number	SHEAVE DIA. (in.)	# OF SHEAVES	THICKNESS (in.)	WIDTH (in.)	NET LENGTH (in.)	THROAT OPENING (in.)	SHEAVE PIN DIA. (in.)	STD WIRE ROPE DIA. (in.)	Weight Lbs.
25	116F25	16	1	8.75	17.5	33.5	3.63	3	7/8	310
25	116H25	16	1	13.75	17.5	33.5	3.63	3	7/8	460
25	118F25	18	1	8.75	19.5	34.5	3	3	7/8	330
25	118H25	18	1	12.75	19.5	34.5	3	3	7/8	630
25	120F25	20	1	9	21.5	38.5	4	3	1	400
25	120H25	20	1	13	21.5	38.5	4	3	1	765
25	214F25	14	2	7.5	15.5	29.5	3	2.5	3/4	250
25	214H25	14	2	11	15.5	29.5	3	2.5	3/4	415
25	216F25	16	2	8.75	17.5	33.75	3.63	3	7/8	340
25	216H25	16	2	13.75	17.5	33.75	3.63	3	7/8	580
25	218F25	18	2	8.75	19.5	35.75	3.63	3	7/8	365
25	218H25	18	2	12.75	19.5	35.75	3.63	3	7/8	665
25	220F25	20	2	9	21.5	38.5	3	3.25	1	445
25	220H25	20	2	13	21.5	38.5	3	3.25	1	810
25	314F25	14	3	9.75	15.5	29.88	3.63	2.5	3/4	285
25	314H25	14	3	13.25	15.5	29.88	3.63	2.5	3/4	445
25	316F25	16	3	8.75	17.5	33.75	3.63	3	7/8	415
25	316H25	16	3	13.75	17.5	33.75	3.63	3	7/8	655
25	318F25	18	3	11.38	19.5	35.75	3	3	7/8	425
25	318H25	18	3	15.38	19.5	35.75	3	3	7/8	725
25	414F25	14	4	12.88	15.5	31.19	3.5	2.5	3/4	425
25	414H25	14	4	16.38	15.5	31.19	3.5	2.5	3/4	645

## 30 TON

WLL* Tons	Model Number	SHEAVE DIA. (in.)	# OF SHEAVES	THICKNESS (in.)	WIDTH (in.)	NET LENGTH (in.)	THROAT OPENING (in.)	SHEAVE PIN DIA. (in.)	STD WIRE ROPE DIA. (in.)	Weight Lbs.
30	120F30	20	1	9	21.5	38.5	3	3.25	1	400
30	120H30	20	1	13	21.5	38.5	3	3.25	1	765
30	130T30	30	1	14.88	33	62.25	3.63	5	1 1/4	1750
30	214F30	14	2	7.5	15.5	31	3.63	2.5	3/4	250
30	214H30	14	2	11	15.5	31	3.63	2.5	3/4	410
30	216F30	16	2	8.75	17.5	33.75	3.63	3	7/8	340
30	216H30	16	2	13.75	17.5	33.75	3.63	3	7/8	580
30	314F30	14	3	9.75	15.5	29.88	3.63	3	3/4	285
30	314H30	14	3	13.25	15.5	29.88	3.63	3	3/4	445
30	316F30	16	3	11.38	17.5	33.75	3.63	3	7/8	415
30	316H30	16	3	16.38	17.5	33.75	3.63	3	7/8	655
30	318F30	18	3	11.38	19.5	35.34	3	3	7/8	425
30	318H30	18	3	15.38	19.5	35.34	3	3	7/8	725
30	320F30	20	3	11.75	21.5	38.5	3	3.25	1	515
30	320H30	20	3	15.75	21.5	38.5	3	3.25	1	880
30	414F30	14	4	12.88	15.5	31.19	3.5	2.5	3/4	425
30	414H30	14	4	16.38	15.5	31.19	3.5	2.5	3/4	645
30	516F30	16	5	17.63	17.5	33.81	3.5	3	7/8	520
30	516H30	16	5	22.63	17.5	33.81	3.5	3	7/8	760

# BLOCKS- HI-LIFT BLOCKS

## 35 TON

WLL* Tons	Model Number	SHEAVE DIA. (in.)	# OF SHEAVES	THICKNESS (in.)	WIDTH (in.)	NET LENGTH (in.)	THROAT OPENING (in.)	SHEAVE PIN DIA. (in.)	STD WIRE ROPE DIA. (in.)	Weight Lbs.
35	124T35	24	1	11.5	26.63	56.81	3.75	3.5	1 1/8	1255
35	124TF35	24	1	12	26.63	50.81	3.75	3.5	1 1/8	830
35	216F35	16	2	8.75	17.5	36.38	3.75	3	7/8	385
35	216H35	16	2	13.75	17.5	36.38	3.75	3	7/8	625
35	218F35	18	2	8.75	19.5	38.5	3.75	3	7/8	410
35	218H35	18	2	12.75	19.5	38.5	3.75	3	7/8	710
35	220F35	20	2	9	21.5	41.13	3.75	3.25	1	495
35	220H35	20	2	13	21.5	41.13	3.75	3.25	1	860
35	224T35	24	2	11.5	26	56.81	3.75	3.5	1 1/8	1360
35	224TF35	24	2	12	26.63	50.81	3.75	3.5	1 1/8	945
35	314F35	14	3	975	15.5	33.5	3.63	2.5	3/4	365
35	314H35	14	3	13.25	15.5	33.5	3.63	2.5	3/4	585
35	316F35	16	3	11.38	17.5	36.38	3.75	3	7/8	455
35	316H35	16	3	16.38	17.5	36.38	3.75	3	7/8	695
35	318F35	18	3	11.38	19.5	38.38	3.75	3	7/8	465
35	318H35	18	3	15.38	19.5	38.38	3.75	3	7/8	765
35	320F35	20	3	11.75	21.5	41.38	3.75	3.25	1	565
35	320H35	20	3	15.75	21.5	41.38	3.75	3.25	1	930
35	414F35	14	4	12.88	15.5	34.06	3.75	2.5	3/4	465
35	414H35	14	4	16.38	15.5	34.06	3.75	2.5	3/4	685
35	416F35	16	4	14.75	17.5	36.38	3.75	3	7/8	585
35	416H35	16	4	19.75	17.5	36.38	3.75	3	7/8	825
35	514F35	14	5	15.75	15.5	33.94	3.75	2.5	3/4	600
35	514H35	14	5	19.25	15.5	33.94	3.75	2.5	3/4	820
35	516F35	16	5	17.63	17.5	37.94	3.75	3	7/8	780
35	516H35	16	5	22.63	17.5	37.94	3.75	3	7/8	1020

## 40 TON

WLL* Tons	Model Number	SHEAVE DIA. (in.)	# OF SHEAVES	THICKNESS (in.)	WIDTH (in.)	NET LENGTH (in.)	THROAT OPENING (in.)	SHEAVE PIN DIA. (in.)	STD WIRE ROPE DIA. (in.)	Weight Lbs.
40	124T40	24	1	11.5	26.63	56.68	3.75	3.5	1 1/8	1255
40	124TF40	24	1	12	26.63	56.68	3.75	3.5	1 1/8	830
40	130T40	30	1	14.88	33	65.81	3.75	5	1 1/4	1750
40	220F40	20	2	9	21.5	41.88	3.75	3.25	1	495
40	220H40	20	2	13	21.5	41.88	3.75	3.25	1	860
40	224T40	24	2	11.5	26	56.81	3.75	3.5	1 1/8	1360
40	224TF40	24	2	12	26.63	50.81	3.75	3.5	1 1/8	945
40	230T40	30	2	14.88	33	65.81	3.75	5	1 1/4	1900
40	316F40	16	3	11.38	17.5	35.38	3.75	3	7/8	455
40	316H40	16	3	16.38	17.5	35.38	3.75	3	7/8	695
40	318F40	18	3	11.38	19.5	38.88	3.75	3	7/8	465
40	318H40	18	3	15.38	19.5	38.88	3.75	3	7/8	765
40	320F40	20	3	11.75	21.5	42.06	3.75	3.25	1	565
40	320H40	20	3	15.75	21.5	42.06	3.75	3.25	1	930
40	414F40	14	4	13	15.5	35.25	3.75	2.5	3/4	465
40	414H40	14	4	16.5	15.5	35.25	3.75	2.5	3/4	685
40	416F40	16	4	14.75	17.5	37.88	3.75	3	7/8	585
40	416H40	16	4	19.75	17.5	37.88	3.75	3	7/8	825
40	418F40	18	4	14.75	19.5	39.63	3.75	3	7/8	640
40	418H40	18	4	18.75	19.5	39.63	3.75	3	7/8	940
40	514F40	14	5	15.75	15.5	34.06	3.75	2.5	3/4	600
40	514H40	14	5	19.25	15.5	34.06	3.75	2.5	3/4	820
40	516F40	16	5	17.63	17.5	37.88	3.75	3	7/8	770
40	516H40	16	5	22.63	17.5	37.88	3.75	3	7/8	1040
40	616F40	16	6	20	17.5	37.88	3.75	3	7/8	830
40	616H40	16	6	25	17.5	37.88	3.75	3	7/8	1100



# BLOCKS- HI-LIFT BLOCKS

## 45 TON

WLL* Tons	Model Number	SHEAVE DIA. (in.)	# OF SHEAVES	THICKNESS (in.)	WIDTH (in.)	NET LENGTH (in.)	THROAT OPENING (in.)	SHEAVE PIN DIA. (in.)	STD WIRE ROPE DIA. (in.)	Weight Lbs.
45	220F45	20	2	9	21.5	41.88	4.25	3.25	1	640
45	220H45	20	2	13	21.5	41.88	4.25	3.25	1	900
45	224T45	24	2	11.5	26.63	58.69	4.25	3.5	1 1/8	1000
45	224TF45	24	2	12	26.63	52.69	4.25	3.5	1 1/8	1375
45	318F45	18	3	11.38	19.5	39.38	4.25	3	7/8	525
45	318H45	18	3	15.38	19.5	39.38	4.25	3	7/8	825
45	320F45	20	3	11.75	21.5	42.13	4.25	3.25	1	535
45	320H45	20	3	15.75	21.5	42.13	4.25	3.25	1	900
45	416F45	16	4	14.75	17.5	37.5	4.25	3	7/8	705
45	416H45	16	4	19.75	17.5	38.5	4.25	3	7/8	975
45	418F45	18	4	15.25	19.5	41.63	4.25	3	7/8	760
45	418H45	18	4	19.25	19.5	41.63	4.25	3	7/8	1050
45	514F45	14	5	15.75	15.5	35.5	4.25	2.5	3/4	605
45	514H45	14	5	19.25	15.5	35.5	4.25	2.5	3/4	970
45	516F45	16	5	17.63	17.5	37.5	4.25	3	7/8	820
45	516H45	16	5	22.63	17.5	37.5	4.25	3	7/8	1090

## 50 TON

WLL* Tons	Model Number	SHEAVE DIA. (in.)	# OF SHEAVES	THICKNESS (in.)	WIDTH (in.)	NET LENGTH (in.)	THROAT OPENING (in.)	SHEAVE PIN DIA. (in.)	STD WIRE ROPE DIA. (in.)	Weight Lbs.
50	130T50	30	1	14.88	33	67.69	4.25	5	1 1/4	2000
50	136T50	36	1	14.88	39	74.25	4.25	5		2500
50	220F50	20	2	9	21.5	41.88	4.25	3.25	1	535
50	220H50	20	2	13	21.5	41.88	4.25	3.25	1	900
50	224T50	24	2	11.5	26.63	58.69	4.25	3.5	1 1/8	1375
50	224TF50	24	2	12	26.63	52.69	4.25	3.5	1 1/8	1000
50	230T50	30	2	14.88	33	67.69	4.25	5	1 1/4	2160
50	318F50	18	3	11.38	19.5	39.38	4.25	3	7/8	525
50	318H50	18	3	15.38	19.5	39.38	4.25	3	7/8	825
50	320F50	20	3	11.75	21.5	42.13	4.25	3.25	1	605
50	320H50	20	3	15.75	21.5	42.13	4.25	3.25	1	970
50	324T50	24	3	16.38	26.63	62.31	4.25	3.5	1 1/8	1740
50	324TF50	24	3	12	26.63	52.69	4.25	3.5	1 1/8	1000
50	416F50	16	4	14.75	17.5	37.5	4.25	3	7/8	705
50	416H50	16	4	19.75	17.5	37.5	4.25	3	7/8	975
50	418F50	18	4	15.25	19.5	41.63	4.25	3	7/8	760
50	418H50	18	4	19.25	19.5	41.63	4.25	3	7/8	1050
50	420F50	20	4	15.5	22	42.13	4.25	3.25	1	800
50	420H50	20	4	19.5	22	42.13	4.25	3.25	1	1200
50	516F50	16	5	17.63	17.5	37.5	4.25	3	7/8	820
50	516H50	16	5	22.63	17.5	37.5	4.25	3	7/8	1090
50	518F50	18	5	16.63	20	41.63	4.25	3	7/8	1010
50	518H50	18	5	20.63	20	41.63	4.25	3	7/8	1300
50	616F50	16	6	20	17.5	37.5	4.25	3	7/8	930
50	616H50	16	6	25	17.5	37.5	4.25	3	7/8	1200

# BLOCKS- HI-LIFT BLOCKS

## 60 TON

WLL* Tons	Model Number	SHEAVE DIA. (in.)	# OF SHEAVES	THICKNESS (in.)	WIDTH (in.)	NET LENGTH (in.)	THROAT OPENING (in.)	SHEAVE PIN DIA. (in.)	STD WIRE ROPE DIA. (in.)	Weight Lbs.
60	130T60	30	1	14.88	33	71.75	5.13	5	1 1/4	2100
60	224T60	24	2	11.5	26.63	65.75	5.13	3.5	1 1/8	1650
60	224TF60	24	2	12	26.63	59.75	5.13	3.5	1 1/8	1100
60	230T60	30	2	14.88	33	71.75	5.13	5	1 1/4	2250
60	320F60	20	3	11.75	21.5	45.88	5.13	3.5	1	945
60	320H60	20	3	15.75	21.5	45.88	5.13	3.5	1	1345
60	324T60	24	3	16.38	26.63	65.75	5.13	3.5	1 1/8	1950
60	324TF60	24	3	15.38	26.63	59.75	5.13	3.5	1 1/8	1450
60	330T60	30	3	19.94	33	71.75	5.13	5	1 1/4	2735
60	418F60	18	4	16.25	19.75	45.88	5.13	3	7/8	1010
60	418H60	18	4	20.25	19.75	45.88	5.13	3	7/8	1300
60	420F60	20	4	17.25	22	48.38	5.13	3.5	1	1110
60	420H60	20	4	21.25	22	48.38	5.13	3.5	1	1510
60	516F60	16	5	18.63	17.5	43.5	5.13	3	7/8	1060
60	516H60	16	5	23.63	17.5	43.5	5.13	3	7/8	1330
60	518F60	18	5	18.63	20	56.5	5.13	3	7/8	1110
60	518H60	18	5	18.63	20	56.5	5.13	3	7/8	1400
60	520F60	20	5	19.75	22	48.38	5.13	3.5	1	1315
60	520H60	20	5	23.75	22	48.38	5.13	4	1	1715

## 65 TON

WLL* Tons	Model Number	SHEAVE DIA. (in.)	# OF SHEAVES	THICKNESS (in.)	WIDTH (in.)	NET LENGTH (in.)	THROAT OPENING (in.)	SHEAVE PIN DIA. (in.)	STD WIRE ROPE DIA. (in.)	Weight Lbs.
65	420F65	20	4	17.25	22	48.38	5.13	3.5	1	1110
65	420H65	20	4	21.25	22	48.38	5.13	3.5	1	1510
65	516F65	16	5	18.63	17.5	43.5	5.13	3	7/8	830
65	516H65	16	5	23.63	17.5	43.5	5.13	3	7/8	1100
65	518F65	18	5	18.63	20	56.5	5.13	3	7/8	1100
65	518H65	18	5	22.63	20	56.5	5.13	3	7/8	1400
65	520F65	20	5	19.75	22	48.38	5.13	3.5	1	1315
65	520H65	20	5	23.75	22	48.38	5.13	3.5	1	1715
65	620F65	20	6	22.25	22	48.13	5.38	3.5	1	1450
65	620H65	20	6	26.25	22	48.13	5.38	3.5	1	1850

## 75 TON

WLL* Tons	Model Number	SHEAVE DIA. (in.)	# OF SHEAVES	THICKNESS (in.)	WIDTH (in.)	NET LENGTH (in.)	THROAT OPENING (in.)	SHEAVE PIN DIA. (in.)	STD WIRE ROPE DIA. (in.)	Weight Lbs.
75	136T75	36	1	14.88	42.5	80.81	5.88	5		2800
75	230T75	30	2	14.88	33	74.31	5.88	5	1 1/4	2500
75	236T75	36	2	14.88	42.5	80.81	5.88	5		3000
75	320F75	20	3	11.75	21.5	50.25	5.88	3.5	1	1045
75	320H75	20	3	15.75	21.5	50.25	5.88	3.5	1	1445
75	324T75	24	3	16.38	26.56	68.31	5.88	3.5	1 1/8	2220
75	324TF75	24	3	15.38	26.63	62.44	5.88	3.5	1 1/8	1550
75	330T75	30	3	19.94	33	74.31	5.88	5	1 1/4	2835
75	420F75	20	4	16.75	22	50.63	5.88	3.5	1	1275
75	420H75	20	4	20.75	22	50.63	5.88	3.5	1	1675
75	424T75	24	4	19.75	26.5	68.31	5.88	3.5	1 1/8	2200
75	424TF75	24	4	20.25	26.63	62.44	5.88	3.5	1 1/8	1770
75	430T75	30	4	23.31	33	74.31	5.88	5	1 1/4	3625
75	520F75	20	5	19.75	22	51	5.88	3.5	1	1435
75	520H75	20	5	23.75	22	51	5.88	3.5	1	1835
75	620F75	20	6	22.25	22	49.5	5.88	3.5	1	1550
75	620H75	20	6	26.25	22	49.5	5.88	3.5	1	1950





# BLOCKS- HI-LIFT BLOCKS

## 80 TON

WLL* Tons	Model Number	SHEAVE DIA. (in.)	# OF SHEAVES	THICKNESS (in.)	WIDTH (in.)	NET LENGTH (in.)	THROAT OPENING (in.)	SHEAVE PIN DIA. (in.)	STD WIRE ROPE DIA. (in.)	Weight Lbs.
80	324T80	24	3	16.38	26.63	68.31	5.88	3.5	1 1/8	2220
80	324TF80	24	3	15.38	26.63	62.44	5.88	3.5	1 1/8	1550
80	420F80	20	4	16.75	21.5	50.5	5.88	3.5	1	1275
80	420H80	20	4	20.75	21.5	50.5	5.88	3.5	1	1675
80	424T80	24	4	19.75	26.5	68.44	5.88	3.5	1 1/8	2200
80	424TF80	24	4	20.25	26.63	62.44	5.88	3.5	1 1/8	1770
80	520F80	20	5	19.75	22	51	5.88	3.5	1	1435
80	520H80	20	5	23.75	22	51	5.88	3.5	1	1835
80	524T80	24	5	24.38	26.63	68.81	5.88	3.5	1 1/8	2450
80	524TF80	24	5	24.88	26.63	62.81	5.88	3.5	1 1/8	2140

## 90 TON

WLL* Tons	Model Number	SHEAVE DIA. (in.)	# OF SHEAVES	THICKNESS (in.)	WIDTH (in.)	NET LENGTH (in.)	THROAT OPENING (in.)	SHEAVE PIN DIA. (in.)	STD WIRE ROPE DIA. (in.)	Weight Lbs.
90	324T90	24	3	16.38	26.63	70.31	5.38	3.5	1 1/8	2385
90	324TF90	24	3	15.38	26.63	30.75	5.38	3.5	1 1/8	1715
90	424T90	24	4	19.75	26.5	70.18	5.38	3.5	1 1/8	2365
90	424TF90	24	4	20.25	26.63	60.75	5.38	3.5	1 1/8	1935
90	520F90	20	5	19.75	22	53.5	5.38	3.5	1	1600
90	520H90	20	5	23.75	22	53.5	5.38	3.5	1	2000
90	524TF90	24	5	24.88	26.63	64.88	5.38	3.5	1 1/8	2615
90	620F90	20	6	22.25	22	53.5	5.38	3.5	1	1750
90	620H90	20	6	26.25	22	53.5	5.38	3.5	1	2150
90	624T90	24	6	28	26	70.25	5.38	3.5	1 1/8	3170
90	624TF90	24	6	27	26.63	64.75	5.38	3.5	1 1/8	2800

## 100 TON

WLL* Tons	Model Number	SHEAVE DIA. (in.)	# OF SHEAVES	THICKNESS (in.)	WIDTH (in.)	NET LENGTH (in.)	THROAT OPENING (in.)	SHEAVE PIN DIA. (in.)	STD WIRE ROPE DIA. (in.)	Weight Lbs.
100	136T100	36	1	14.88	42.5	86.38	5.38	5		3250
100	236T100	36	2	14.88	42.5	86.38	5.38	5		3450
100	324T100	24	3	16.38	26.63	73.88	5.38	3.5	1 1/8	2535
100	324TF100	24	3	15.38	26.63	67.75	5.38	3.5	1 1/8	1800
100	330T100	30	3	19.94	33	79.88	5.38	5	1 1/4	3175
100	336T100	36	3	19.94	42.5	86.38	5.38	5		3900
100	424T100	24	4	19.75	26.5	73.75	5.38	3.5	1 1/8	2515
100	424TF100	24	4	20.25	26.63	67.75	5.38	3.5	1 1/8	2015
100	430T100	30	4	23.31	36	79.88	5.38	5	1 1/4	3725
100	436T100	36	4	23.31	42.5	86.38	5.38	5		4490
100	520F100	20	5	19.75	22	54.13	5.38	3.5	1	2110
100	520H100	20	5	23.75	22	54.13	5.38	3.5	1	2575
100	524T100	24	5	24.38	26.63	74.25	5.38	3.5	1 1/8	2970
100	524TF100	24	5	24.88	26.63	67.75	5.38	3.5	1 1/8	2500
100	530T100	30	5	28	36	79.88	5.38	5	1 1/4	4530
100	536T100	36	5	28	42.5	86.38	5.38	5		5340
100	620F100	20	6	22.25	22	54.13	5.38	3.5	1	2000
100	620H100	20	6	26.25	22	54.13	5.38	3.5	1	2400
100	624T100	24	6	28	26	74.25	5.38	3.5	1 1/8	3320
100	624TF100	24	6	27	26.63	64.75	5.38	3.5	1 1/8	2875

# BLOCKS- HI-LIFT BLOCKS

## 115 TON

WLL* Tons	Model Number	SHEAVE DIA. (in.)	# OF SHEAVES	THICKNESS (in.)	WIDTH (in.)	NET LENGTH (in.)	THROAT OPENING (in.)	SHEAVE PIN DIA. (in.)	STD WIRE ROPE DIA. (in.)	Weight Lbs.
115	424T115	24	4	19.75	26.5	73.75	5.38	3.5	1 1/8	2515
115	424TF115	24	4	20.25	26.63	67.75	5.38	3.5	1 1/8	2015
115	524TF115	24	5	24.88	26.63	67.75	5.38	3.5	1 1/8	2500
115	620F115	20	6	22.25	22	54.13	5.38	3.5	1	2000
115	620H115	20	6	26.25	22	54.13	5.38	3.5	1	2400
115	624T115	24	6	28	26	74.25	5.38	3.5	1 1/8	3320
115	624TF115	24	6	27	26.63	64.75	5.38	3.5	1 1/8	2875

## 125 TON

WLL* Tons	Model Number	SHEAVE DIA. (in.)	# OF SHEAVES	THICKNESS (in.)	WIDTH (in.)	NET LENGTH (in.)	THROAT OPENING (in.)	SHEAVE PIN DIA. (in.)	STD WIRE ROPE DIA. (in.)	Weight Lbs.
125	236T125	36	2	14.88	42.5	87.38	5.5	5		3600
125	330T125	30	3	19.94	33	80.88	5.5	5	1 1/4	3200
125	336T125	36	3	19.94	42.5	87.38	5.5	5		3930
125	424T125	24	4	19.75	26.5	74.88	5.5	3.5	1 1/8	2670
125	424TF125	24	4	20.25	26.63	68.88	5.5	3.5	1 1/8	2150
125	430T125	30	4	23.31	36	80.88	5.5	5	1 1/4	3825
125	436T125	36	4	23.31	42.5	87.38	5.5	5		4590
125	524T125	24	5	24.38	26.63	75.38	5.5	3.5	1 1/8	3000
125	524TF125	24	5	27	26.63	69.38	5.5	3.5	1 1/8	2530
125	624T125	24	6	28	26	75.38	5.5	3.5	1 1/8	3350
125	624TF125	24	6	27	26.63	69.38	5.5	3.5	1 1/8	2975

## 135 TON

WLL* Tons	Model Number	SHEAVE DIA. (in.)	# OF SHEAVES	THICKNESS (in.)	WIDTH (in.)	NET LENGTH (in.)	THROAT OPENING (in.)	SHEAVE PIN DIA. (in.)	STD WIRE ROPE DIA. (in.)	Weight Lbs.
135	424T135	24	4	19.75	26.5	74.88	5.5	3.5	1 1/8	2670
135	424TF135	24	4	20.25	26.63	68.88	5.5	3.5	1 1/8	2150

## 150 TON

WLL* Tons	Model Number	SHEAVE DIA. (in.)	# OF SHEAVES	THICKNESS (in.)	WIDTH (in.)	NET LENGTH (in.)	THROAT OPENING (in.)	SHEAVE PIN DIA. (in.)	STD WIRE ROPE DIA. (in.)	Weight Lbs.
150	330T150	30	3	19.94	33	80.88	5.5	5	1 1/4	3200
150	336T150	36	3	19.94	42.5	87.88	5.5	5		3930
150	424T150	24	4	19.75	26.5	74.88	5.5	3.5	1 1/8	2670
150	424TF150	24	4	20.25	26.63	68.88	5.5	3.5	1 1/8	2150
150	430T150	30	4	23.31	36	80.88	5.5	5	1 1/4	3825
150	436T150	36	4	23.31	42.5	87.88	5.5	5		4590
150	524T150	24	5	24.38	26.63	75.38	5.5	3.5	1 1/8	3000
150	524TF150	24	5	24.88	26.63	69.38	5.5	3.5	1 1/8	2530
150	530T150	30	5	28	36	86.75	5.5	5	1 1/4	4560
150	536T150	36	5	28	42.5	87.88	5.5	5		5370
150	624T150	24	6	28	26	75.38	5.5	3.5	1 1/8	3350
150	624TF150	24	6	27	26.63	69.38	5.5	3.5	1 1/8	2975
150	630T150	30	6	31.75	36	86.75	5.5	5	1 1/4	4650
150	636T150	36	6	31.75	42.5	87.88	5.5	5		5600

## BLOCKS- HI-LIFT BLOCKS

### 200 TON

WLL* Tons	Model Number	SHEAVE DIA. (in.)	# OF SHEAVES	THICKNESS (in.)	WIDTH (in.)	NET LENGTH (in.)	THROAT OPENING (in.)	SHEAVE PIN DIA. (in.)	STD WIRE ROPE DIA. (in.)	Weight Lbs.
200	430T200	30	4	23.31	36	89	6	5	1 1/4	4200
200	436T200	36	4	23.31	42.5	95.5	6	5		4965
200	530T200	30	5	28	36	89	6	5	1 1/4	4700
200	536T200	36	5	28	42.5	95.5	6	5		5600
200	630T200	30	6	31.75	36	89	6	5	1 1/4	4900
200	636T200	36	6	31.75	42.5	95.5	6	5		5900

### 250 TON

WLL* Tons	Model Number	SHEAVE DIA. (in.)	# OF SHEAVES	THICKNESS (in.)	WIDTH (in.)	NET LENGTH (in.)	THROAT OPENING (in.)	SHEAVE PIN DIA. (in.)	STD WIRE ROPE DIA. (in.)	Weight Lbs.
250	630T250	30	6	31.75	36	93.5	7.5	5	1 1/4	5120
250	636T250	36	6	31.75	42.5	99.75	7.5	5		6125

### 300 TON

WLL* Tons	Model Number	SHEAVE DIA. (in.)	# OF SHEAVES	THICKNESS (in.)	WIDTH (in.)	NET LENGTH (in.)	THROAT OPENING (in.)	SHEAVE PIN DIA. (in.)	STD WIRE ROPE DIA. (in.)	Weight Lbs.
300	530T300	30	5	30	36	94.25	8	5	1 1/4	6400
300	536T300	36	5	28	42.5	100.75	7.5	5		7025
300	630T300	30	6	33.75	36	94.25	7.5	5	1 1/4	6700
300	636T300	36	6	31.75	42.5	100.75	7.5	5		7370

Custom Miller Blocks are available to suit your special requirements.  
Contact us for more information.

